

## Op-Amp Applications (DC)

### Linear Functions

#### Milestone 0

Design and build a circuit with two inputs  $x$  and  $y$  and an output  $z$  such that

$$V_z = -4.55V_x - 2.21V_y \quad (2.1)$$

The design should use a single 741 op-amp and a  $15\text{ k}\Omega$  feedback resistor. Build it at one end of the breadboard and don't dismantle it as it will be needed again later. Check the circuit by tabulating the output for (four) combinations of positive, negative and zero inputs. Create the inputs using one of the methods shown in Figure 2.1, adjust the range on your DVM as necessary to maximise the accuracy of measurements, and remember to indicate the units of all quantities.

#### Milestone 1

Refer to circuit 2.2 and design, build, and test a second circuit with two inputs  $p$  and  $q$  and an output  $r$  and such that

$$V_r = 2.10V_p - 3.19V_q \quad (2.2)$$

Once again use a single 741 op-amp and a  $15\text{ k}\Omega$  feedback resistor. Use standard (E12) values for  $R_p$  and  $R_q$  selected so that the impedance of both inputs are matched. Test the circuit as above. [Note: You will need to set  $V_p$  first and then  $V_q$ , why?]

#### Milestone 2

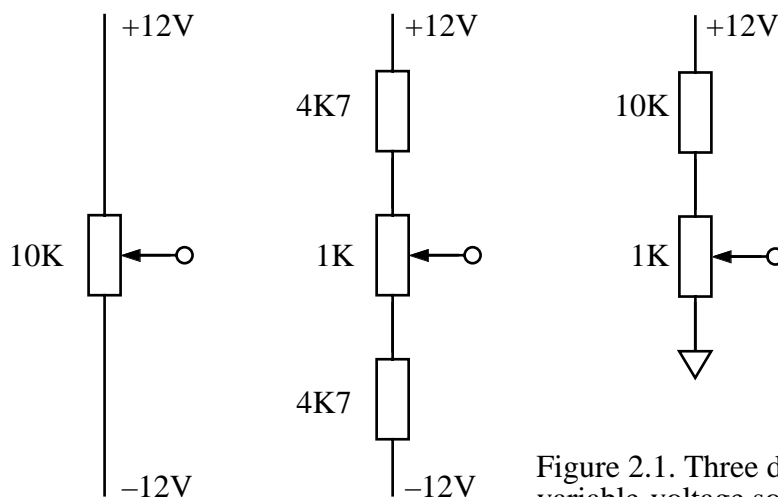
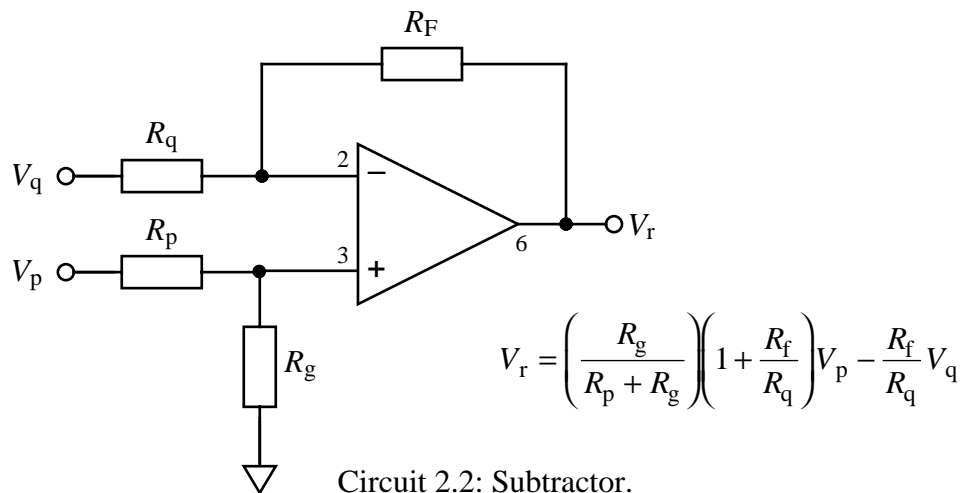

Figure 2.1. Three different variable-voltage sources.



Equations 2.1 and 2.2 can be rearranged so that

$$\begin{aligned} 1.00V_z &= -4.55V_x - 2.21V_y \\ 3.19V_q &= +2.10V_p - 1.00V_r \end{aligned} \quad (2.3)$$

Connect the two circuits you built earlier so that  $V_z = V_p = \lambda$  and  $V_y = V_r = \mu$  and you have built an 'analogue computer' that solves the simultaneous equations

$$\begin{aligned} 4.55V_1 &= -1.00\lambda - 2.21\mu \\ 3.19V_2 &= +2.10\lambda - 1.00\mu \end{aligned} \quad (2.4)$$

Test the circuit by using it to find values of  $\lambda$  and  $\mu$  when  $V_1 = 0.25 \text{ V}$  and  $V_2 = 0.50 \text{ V}$ . How accurate are the values?

### Milestone 3

#### Deviations From the Ideal Model

Build circuit 2.3 with  $R_1 = 0 \Omega$  (*i.e.* a piece of wire!) and  $R_2 = 100 \Omega$  and measure  $V_{\text{out}}$ . Explain why, in this circuit,  $V_{\text{out}}/1000$  is equal to the input offset-voltage  $V_{\text{ios}}$  of the 741. Compare the value for  $V_{\text{ios}}$  for your 741 with the datasheet value. Now, incorporate a  $10 \text{ k}\Omega$  **offset-null** potentiometer, (connect the wiper to the  $-12\text{V}$  supply and its other terminals to pins 1 and 5 of the 741), and adjust it to null  $V_{\text{out}}$ . ready for the next mile.

### Milestone 4

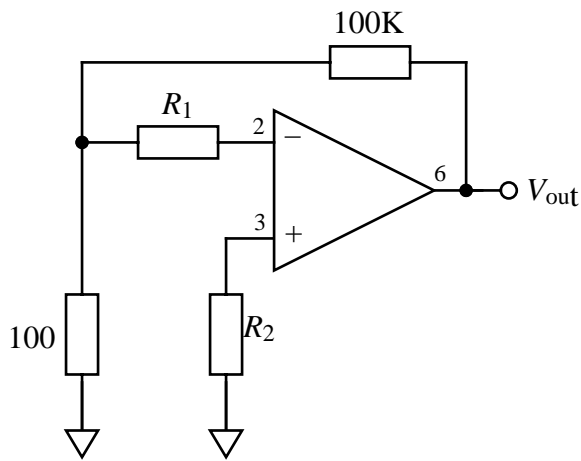

Circuit 2.3: Offset test circuit

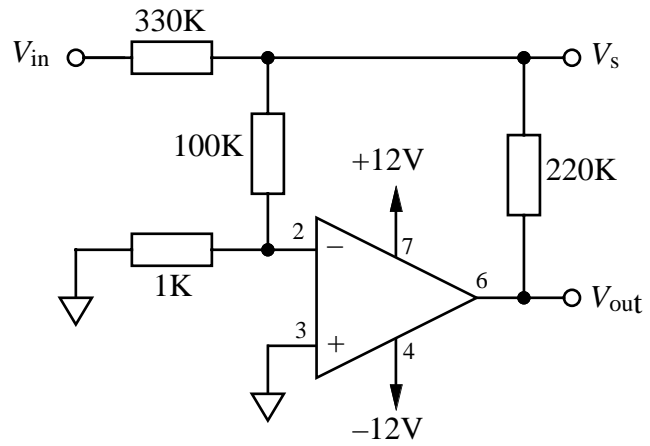

Circuit 2.4: Open-loop gain test circuit

Next, measure  $V_{out}$  with  $R_1 = 0 \Omega$  before and after replacing  $R_2$  with  $R_2 = 100 \text{ k}\Omega$ . Hence deduce  $I_{B+}$  the **input bias-current** associated with the non-inverting input. Swap the values of  $R_1$  and  $R_2$  and hence determine  $I_{B-}$ .

Finally, using  $R_1 = 1 \text{ M}\Omega$  and  $R_2 = 1 \text{ M}\Omega$ , determine the 741's **input offset-current**  $I_{B+} - I_{B-}$  and check it is consistent with your previous measurements.

### Milestone 5

Assume the op-amp has open-loop gain  $A$ . and analyse circuit 2.4 to find how  $V_{out}$  depends on  $V_s$ . Build the circuit and use it to measure the open-loop gain of a 741 op-amp. You will need to null the amplifier offset carefully and make measurements with  $V_{in} = 0 \text{ V}$ ,  $+12 \text{ V}$ ,  $-12 \text{ V}$ . Open-loop gains vary greatly between devices so you may want to try other higher or lower values for the  $100 \Omega$  resistor.

### End of Extra Mile